



INSTRUCTIONS for SDGi Micro Power Lock – Single Open Out

The lock and bracket come completely assembled so you can see how they will mount on the door.

If you have any queries then either visit our website: www.gingersspark.co.uk email: mike@gingersspark.co.uk telephone: 0161-483 4747

Components

- SDGi bracket with 3 no fixings to suit an aluminium door
- 1 no SDGi micro power lock already fitted to the sliding plate
- 1 no armature on a sliding plate within a C section armature housing with 3 no fixings
- 2 No allen keys for the SDGi bracket and the small grub screws on the armature
- 1 no PCB

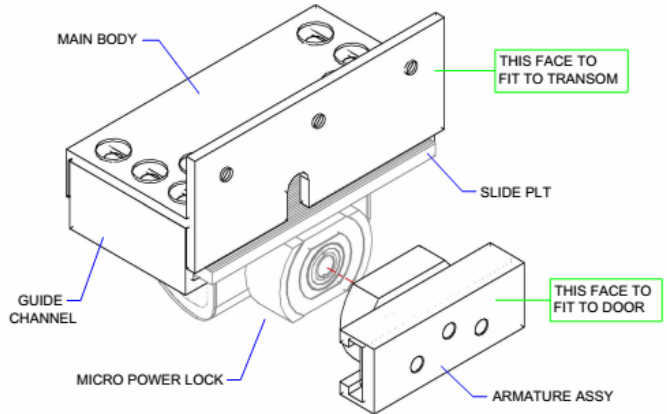

Electrical

1. The cables from the lock can be run into the transom through the n cut out in the SDGi bracket
2. The red and black cables are the power cables the other 3 cables are for the anti tamper function so if this is not required then these can be snipped off
3. The PCB can be located either in the transom or within the operator and secured with the self-adhesive feet – NB DO NOT remove the grey insulating board.
4. The red (+) and black (-) wires from the lock to locate in the smaller terminal block L- and L+ as **Image 2**.
5. The power cables from the auto door operator to go into -/+ as **Image 3**.
6. The PCB automatically adjusts to 12v or 24v power.
7. The three other cables (white, grey and dark red) can be snipped off if the anti tamper function is not required.



Image 2



Image 3

Step One

1. With the lock still in the SDGi bracket offer this and the armature up to the door (as above) and in your preferred position, so that they align together as they would if they were installed.
2. Mark the positions of each on the door and frame.

Step Two – Lock to Transom

1. Loosen the 3 fixings on each end of the main body of the SDGi bracket and slide out the lock and plate and set aside.

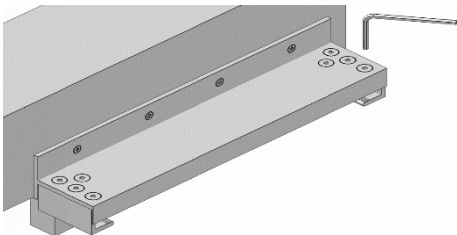

2. Fix the main body to the transom in the most suitable position ensuring that the plate with the lock attached can travel freely under the transom.



Step Three – Armature to Door

1. Loosen the 2 grub screws either side of the armature and slide out and set aside – **Figure 1**.
2. Undo the 3 fixings holding the lipped section (that the armature was slid out of) to the sliding plate and set this lipped section aside – **Figure 3**.
3. As in **Figure 2**, fix this sliding plate to the door where you marked up previously, but only loosely and to the end slot only, so it can slide up and down.
4. Then as in **Figure 3**, using one screw re-attach the lipped section firmly to keep it flush to the sliding plate.
5. Then as in **Figure 4**, slide the armature back in but do not tighten up.
6. Slide the lock (on to the ribbed plate that you removed earlier) into the bracket on the transom and push forward until it meets the armature and the pin sits inside the lock hole and the lock and armature are flush – **Figure 5**.
7. Adjust the armature up and down and sideways until it closes and meets flush with the lock.
8. Nip up the self tapper on the sliding plate (**shown on Figure 3**) which is the only one visible on the plate so that this plate does not move – you then have the exact height the armature needs to be.
9. Open the door, slide out the armature and remove the lipped section.
10. You can then fully secure the sliding plate shown in **Figure 2** with the 3 self tapping fixings provided.
11. Then fix the lipped section as shown in **Figure 3** with all 3 fixings and fully tighten.
12. Slide the armature back in, close the door onto the lock and slide the armature left and right until it is flush with the lock then nip up one of the grub screws either side of the armature (Figure 1), open the door and fully tighten both grub screws and close the door.
13. Then if needs be adjust the lock backwards and forwards to meet flush with the armature and then tighten all 6 fixings as per **Figure 6** – the lock and armature should align perfectly every time



Figure 1



Figure 2



Figure 3

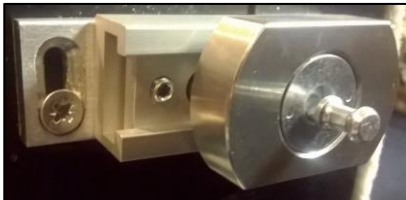

Figure 4

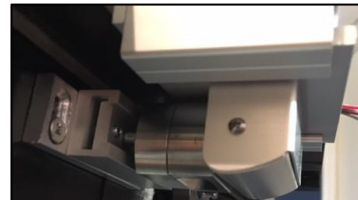

Figure 5

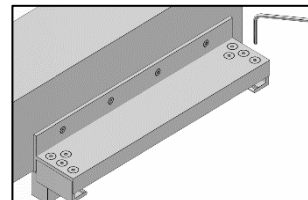

Figure 6

Step Four

1. Once the lock is powered, test opening and closing and ensuring the lock locates smoothly into the armature.
2. It is very important that the lock and armature engage smoothly and flush. It is still possible for minor alterations to positioning/location to be achieved whilst the lock is powered.

Relevant Information

- It is essential that the header frame/transom you are mounting the bracket to is strong enough to accommodate the bracket and its fixings – if in doubt consult with the door supplier.
- Ensure that the fixings supplied are not changed otherwise this will affect the performance of the bracket.
- Do not remove the cover from the back of the lock

Contact Details

www.gingersspark.co.uk
email: mike@gingersspark.co.uk
telephone: 0161-483 4747